

# Introduction to the New Zealand Mathematics & Statistics Curriculum

## Purpose

This resource provides a practical introduction to key concepts from the refreshed New Zealand Mathematics & Statistics curriculum. The activities focus on core mathematical ideas across Number, Algebra, Geometry, Measurement, Statistics, and Probability. They are designed to build familiarity and confidence while keeping literacy demands low and mathematical thinking at the centre of learning.

### Triple-Match Challenge

#### How It Works

1. Print the pages and cut each set into three cards: Topic, Question, Answer.
2. Shuffle all cards and spread them out on a table.
3. Match the Topic, Question, and Answer cards to create complete sets.

**Students Can Use:** Direct problem solving • Mathematical reasoning • Pattern recognition • Process of elimination

## Topics Included

<b>Number</b> Fractions, decimals, percentages, ratios, rates, exponents, and scientific notation.	<b>Algebra</b> Expressions, equations, factorising, graphing, gradients, and linear relationships.
<b>Measurement &amp; Geometry</b> Scale, area, angles, circles, transformations, coordinate geometry, and Pythagoras' theorem.	<b>Statistics &amp; Probability</b> Sampling, data interpretation, tree diagrams, two-way tables, probability investigations, and the Law of Large Numbers.

## Topic

Number

## SCIENTIFIC NOTATION (STANDARD FORM)

## Question

The speed of light is roughly 300,000,000 m/s  
Write this in scientific notation.

## Answer

$3 \times 10^8 \text{ m/s}$

## Topic

Number

### **CUBES AND CUBE ROOTS**

## Question

**Q1. What is  $7^3$**

**Q2. What is  $\sqrt[3]{125}$**

## Answer

**Q1. 343**

**Q2. 5**

## Topic

Number

### **EXPRESS REMAINDERS AS FRACTIONS AND DECIMALS**

## Question

**Q1.  $7 \div 2$  with remainder as a fraction**  
**Q2.  $11 \div 2$  with remainder as a decimal**

## Answer

**Q1.  $3 \frac{1}{2}$**   
**Q2. 5.5**

## Topic

Number

**EVALUATE EXPRESSIONS USING ORDER OF OPERATIONS INCLUDING EXPONENTS**

## Question

$$7 + (6 \times 5^2 + 3)$$

## Answer

**160**

## Topic

Number

**DIVISION BY A FRACTION  
(MULTIPLICATION BY RECIPROCAL)**

## Question

$$18 \div \frac{1}{4}$$

## Answer

$$18 \times 4 = 72$$



## Topic

Number

### **DIVISION BY DECIMALS**

## Question

$$15 \div 0.2$$

**clue: multiply both by ten**

## Answer

$$150 \div 2 = 75$$

## Topic

Number

### **CONVERT FRACTIONS, DECIMALS AND PERCENTAGES**

## Question

**Q1. Write  $\frac{1}{5}$  as a decimal**

**Q2. Write 25% as a fraction**

**Q3. Write 0.67 as a percentage**

## Answer

**Q1. 0.2**

**Q2.  $\frac{25}{100}$  simplified to  $\frac{1}{4}$**

**Q3. 67%**

## Topic

Number

### **ORDER FRACTIONS, DECIMALS AND PERCENTAGES**

## Question

Order the following from smallest to biggest:

**2.5,  $\frac{3}{5}$ , 35%,  $\frac{44}{100}$ , 0.7,  $\frac{6}{8}$**

## Answer

**35%,  $\frac{44}{100}$ ,  $\frac{3}{5}$ , 0.7,  $\frac{6}{8}$ , 2.5**

## Topic

Number

**COMPARE FRACTIONS**  
(Lowest common denominator)

## Question

**Which is bigger:  $\frac{3}{8}$  or  $\frac{5}{12}$**

## Answer

**$\frac{5}{12}$**

## Topic

Number

**FIND EQUIVALENT FRACTIONS,  
SIMPLIFY AND CONVERT MIXED  
NUMBERS AND IMPROPER FRACTIONS**

## Question

- Q1. Write three equivalent fractions to  $\frac{2}{4}$**   
**Q2. Simplify  $\frac{16}{36}$**   
**Q3. Convert  $1\frac{1}{4}$  to a mixed number**

## Answer

- Q1.  $\frac{1}{2}, \frac{3}{6}, \frac{4}{8}, \frac{5}{10}, \frac{20}{40}$  etc.**  
**Q2.  $\frac{4}{9}$**   
**Q3.  $2\frac{3}{4}$**

## Topic

Number

**INCREASE AND DECREASE BY  
FRACTIONS AND PERCENTAGES**

## Question

**Q1. Increase \$30 by 15%**  
**Q2. Decrease \$40 by  $\frac{1}{10}$**

## Answer

**Q1. \$34.50**  
**Q2. \$36**

## Topic

Number

**ADD, SUBTRACT AND MULTIPLY  
FRACTIONS AND PERCENTAGES**

## Question

**Q1.  $\frac{1}{2} - \frac{1}{8}$**

**Q2.  $23\% + 14.5\%$**

**Q3.  $15 \times 20\%$**

## Answer

**Q1.  $\frac{3}{8}$**

**Q2.  $37.5\%$**

**Q3.  $300\%$**

## Topic

Number

### **USE RATIOS TO SHARE UNEQUAL PROPORTIONS**

## Question

**You have 30 lollies to share between Alice and Kahurangi in the ratio of 2:3. How many do each of them get?**

## Answer

**12:18 Alice gets 12, Kahurangi gets 18.**



## Topic

Algebra

## SIMPLIFY ALGEBRAIC EXPRESSIONS

## Question

$$5a + a - 3$$

## Answer

$$6a - 3$$

**Topic**

Algebra

**EXPAND ALGEBRAIC EXPRESSIONS**

**Question**

$$2a(a-3)$$

**Answer**

$$2a^2 - 6a$$



## Topic

Algebra

### **FACTORISE ALGEBRAIC EXPRESSIONS**

## Question

$$x^2 + 4x + 3$$

## Answer

$$(x+3)(x+1)$$

## Topic

Algebra

## SOLVE LINEAR EQUATIONS

## Question

$$5x+4=19$$

## Answer

$$x=3$$



# Topic

Algebra

## EQUATION OF A STRAIGHT LINE ( $y=mx+c$ )

# Question

**Q1. Which line is  $y=2x+5$**

**Q2. What is the equation of the green line?**

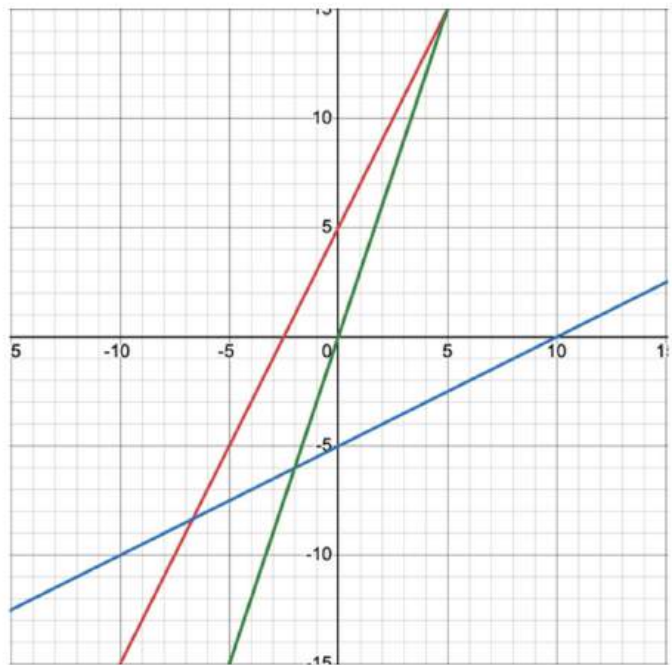

# Answer

**Q1. The red line**

**Q2.  $y=3x$**

# Topic

Algebra

## GRADIENT OF A STRAIGHT LINE

# Question

Q1. What is the gradient of the line?

Q2. What is the y-intercept?

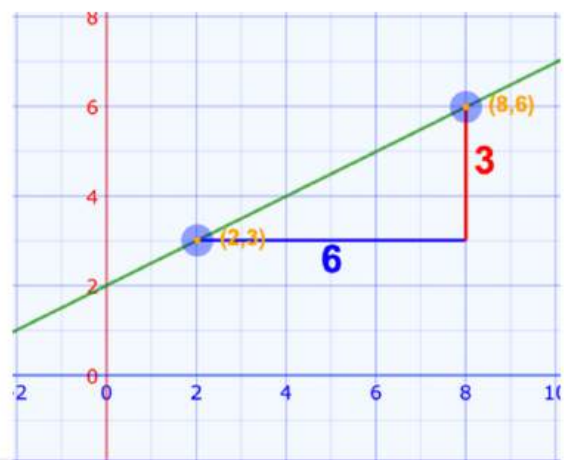

$$\text{Gradient} = \frac{\text{Change in Y}}{\text{Change in X}}$$

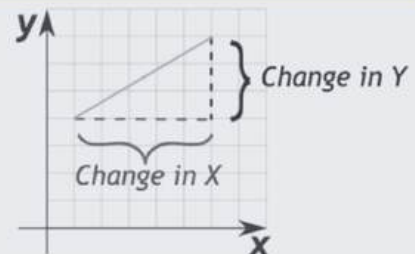

# Answer

Q1.  $\frac{3}{6}$  simplified to  $\frac{1}{2}$  or 0.5

Q2. 2

# Topic

Algebra

## EXPRESS LINEAR RELATIONSHIPS IN GRAPHS

# Question

What is the correlation between sales and temperature: positive, negative or no correlation

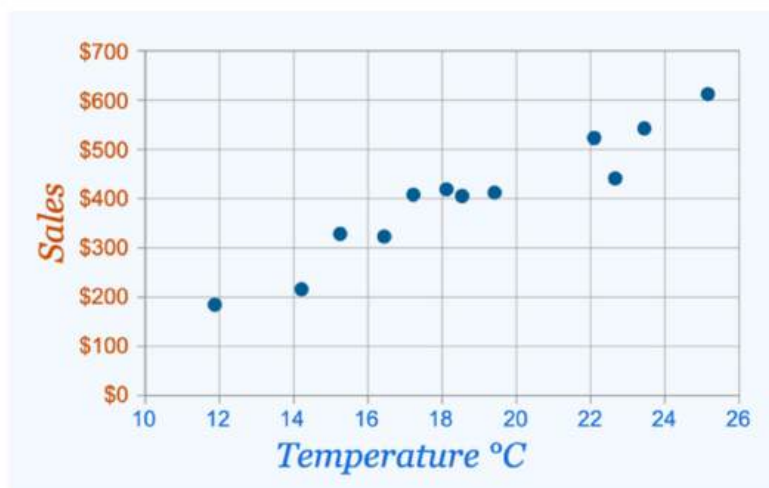

# Answer

**There is a positive correlation  
between sales and temperature**

# Topic

Algebra

## QUADRATIC RELATIONSHIPS IN GRAPHS

# Question

This graph shows  
the quadratic equation  
 $y=x^2$

What word best describes  
the shape of the line?

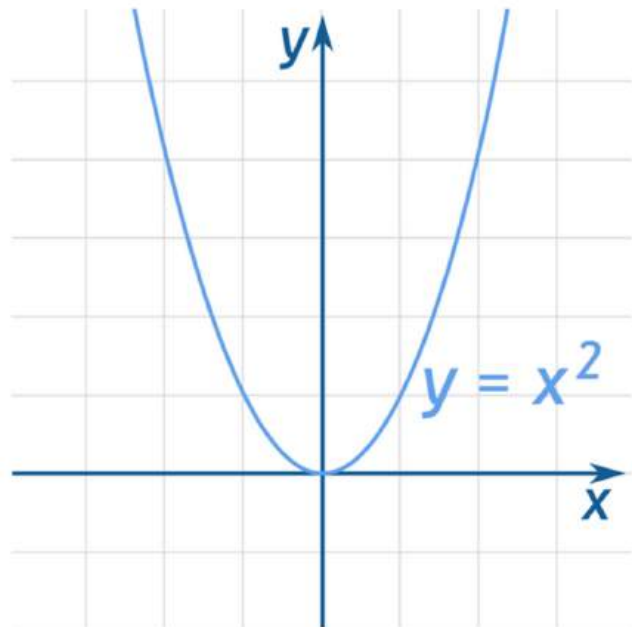

# Answer

It is a parabola

# Topic

Measure

**CONVERT BETWEEN UNITS OF MEASUREMENT  
ROUNDING TO SIGNIFICANT FIGURES AND  
DECIMAL PLACES**

# Question

- Q1. Convert 12.5kg to grams
- Q2. What is 330.26ml rounded to 1 decimal place?
- Q3. What is 36.5sec rounded to one significant figure?

# Answer

- Q1. 12,500g
- Q2. 330.3ml
- Q3. 40sec

## Topic

Measure

$$\text{SPEED} = \text{DISTANCE} / \text{TIME}$$

## Question

**A car travels 20km in 12 minutes,  
how fast is it travelling?**

## Answer

**100km/h**

## Topic

Measure

### **TIME ZONES AND CALENDARS**

## Question

- Q1. The time in Sydney is 2 hours behind Auckland. What time is it in Auckland when it is 3:45pm in Sydney?**
- Q2. Three days ago, yesterday was the day before Sunday. What day will it be tomorrow?**

## Answer

- Q1. 5:45pm**
- Q2. Thursday**

## Topic

Measure

### MAP SCALES

## Question

**Q1. The distance between two towns is 15km. How far apart will they be on a map of scale 1 : 10,000?**

**Q2. The length of a road is 25km. How long will the road be on a map of scale 1 : 20,000?**

## Answer

**Q1. 150cm**

**Q2. 125cm**

# Topic

Measure

## COMPASS DIRECTIONS

# Question



**Q1. What angle do you turn through if you turn from NE to NW anticlockwise?**

**Q2. What angle do you turn through if you turn from E to N clockwise?**

# Answer

**1.  $90^\circ$**

**2.  $270^\circ$**

## Topic

Geometry

### **PYTHAGORAS THEOREM** **$(a^2 + b^2 = c^2)$**

## Question

**Find the missing side in the right-angled triangle:**

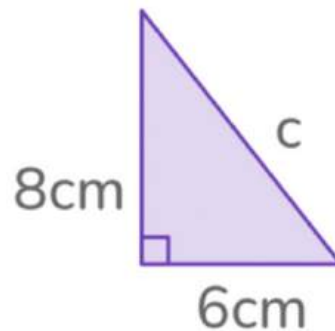

## Answer

$$c = 10\text{cm}$$

# Topic

Geometry

## AREA OF TWO-DIMENSIONAL SHAPES

# Question

What are the areas of these three shapes:

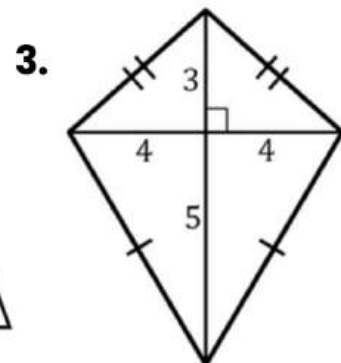
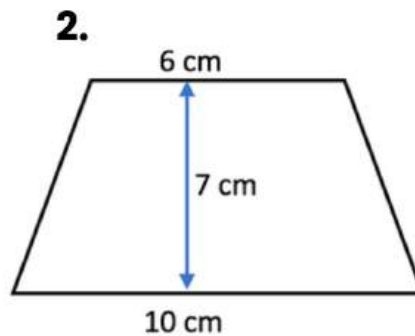
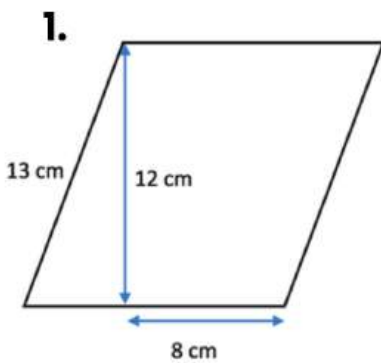

# Answer

1.  $156\text{cm}^2$
2.  $56\text{cm}^2$
3.  $32\text{units}^2$

# Topic

Geometry

## SCALE FACTORS

# Question

**Enlarge the triangle by a scale factor of 5:**

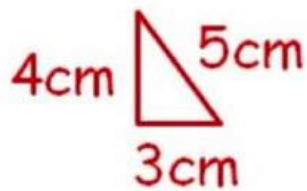

# Answer

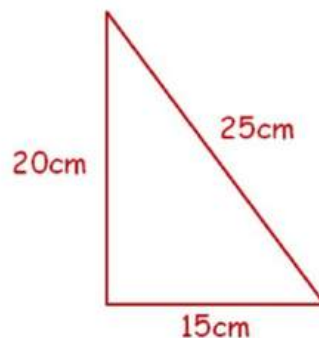

## Topic

Geometry

### **RADIUS, CIRCUMFERENCE AND AREA OF CIRCLES**

## Question

**What is the area and circumference of the circle:**

Give your answer in terms of pi

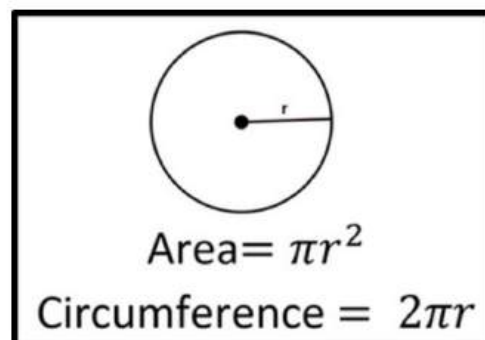
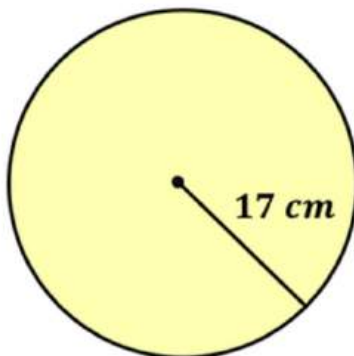

## Answer

$$\text{Area} = 289\pi \text{ cm}^2$$

$$\text{Circumference} = 34\pi \text{ cm}$$

# Topic

Geometry

## INTERSECTING, PARALLEL AND TRANSVERSAL LINES

# Question

What type of lines are these:

1.

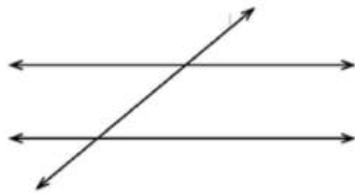

2.



3.

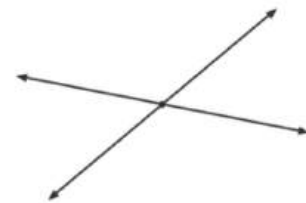

# Answer

1. Transversal
2. Parallel
3. Intersecting

# Topic

Geometry

## UNKNOWN ANGLES ON LINES

# Question

Find the missing angle:

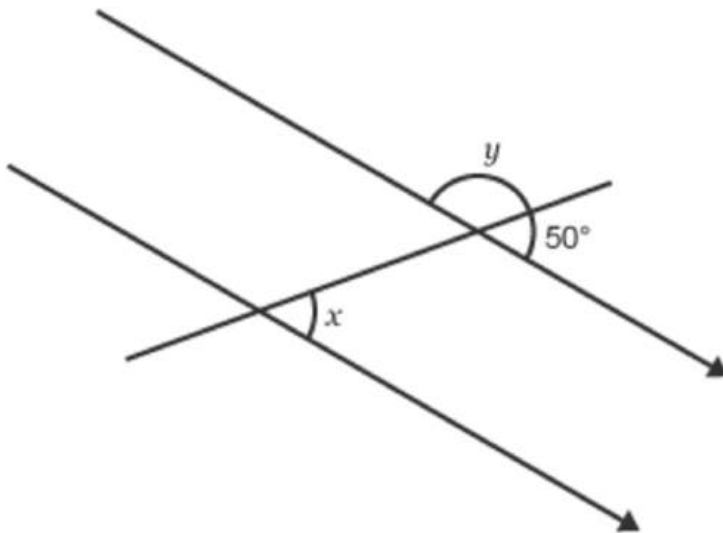

# Answer

$$y = 130^\circ$$

$$x = 50^\circ$$

# Topic

Geometry

## ISOMETRIC DRAWINGS OF THREE-DIMENSIONAL SHAPES

# Question

Name the following 3D shapes:

1.

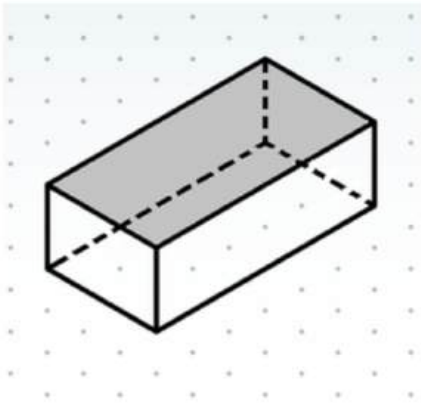

2.

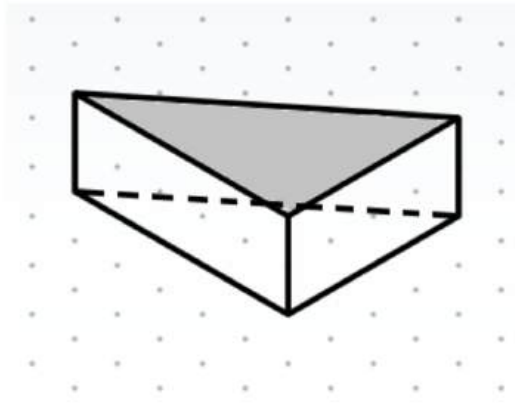

# Answer

1. Rectangular prism
2. Triangular prism

# Topic

Geometry

## TRANSFORMATIONS

# Question

**Name the transformations:**

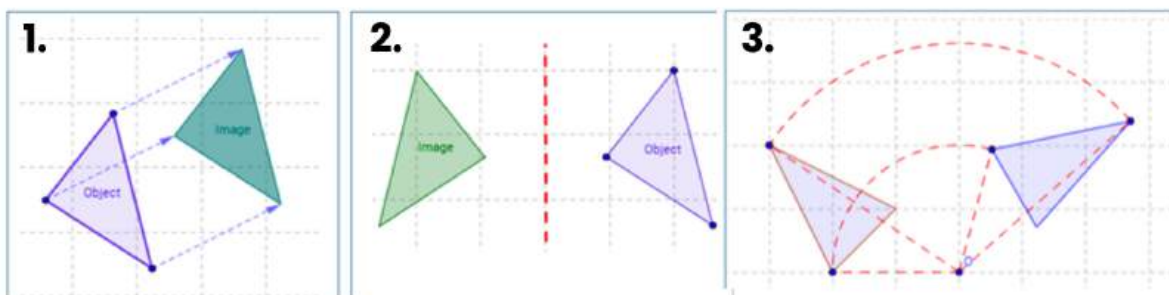

# Answer

- 1. Translation**
- 2. Reflection**
- 3. Rotation**

# Topic







Statistics

## INVESTIGATE USING DATA SETS

# Question

**Q1. How many more Kiku apples are sold than Ambrosia apples in kg?**

**Q2. What is the range of the amount of apples sold across the varieties?**

Variety	Amount of Apples sold (in Kg)
Fuji	
Kiku	
Golden delicious	
Red delicious	
Ambrosia	
Key :  Represents 4 Kg	

# Answer

1. 4kg
2. 10kg - 16kg

# Topic

Statistics

## INVESTIGATE USING SAMPLES

# Question

480 students attend a kura. A teacher asks 50 students which colour they would like the new school jersey to be.

Estimate how many of the 480 students would like a kākāriki jersey.

COLOUR	NUMBER OF STUDENTS
Whero	20
Kākāriki	15
Kōwhai	9
Kikorangi	6

# Answer

144 students

# Topic

Statistics

## IDENTIFY RELEVANT FEATURES IN DISTRIBUTIONS

# Question

**Q1. What is the mode?**

**Q2. What is the outlier?**

**Q3. Consider the statement: The data shows us that most people scored 3 or above. Is this statement correct?**



# Answer

**Q1. A score of 2**

**Q2. A score of 9**

**Q3. The statement is correct**

# Topic

Statistics

## ANALYZING DATA FOR INTERQUARTILE RANGE AND LONG-TERM TREND

# Question

This table represents the sales data over a 10-year period.

Year	1	2	3	4	5	6	7	8	9	10
Sales	45	52	60	64	68	71	74	78	81	85

**Q1. Calculate the Interquartile Range (IQR) of the data set.**

**Q2. Describe the long-term trend of the sales over the 10 years: does the data suggest an overall increase or decrease in sales?**

# Answer

**Q1.  $IQR = 78 - 60 = 18$**

**Q2. Yes, the data suggests an overall increase in sales. Looking at the values in the table, sales start at 45 thousand units and steadily rise to 85 thousand units over the 10-year period, which indicates a positive growth trend.**



# Topic

Probability

## CONDUCT PROBABILITY EXPERIMENTS: TREE DIAGRAMS

# Question

Here's a tree diagram that shows the Crusaders chances of winning their opening two matches

**Q1. What is the probability of winning the first game and losing the second?**

**Q2. What is the probability of winning two games in a row?**

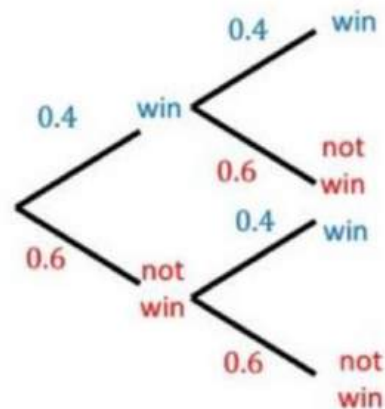

# Answer

**Q1. 0.24**

**Q2. 0.16**

# Topic

Probability

## CONDUCT PROBABILITY EXPERIMENTS: TALLY CHARTS

# Question

Here's a tally chart that shows the favourite subject of 40 students.

Q1. What is the probability of picking a student whose favourite subject is Science?

Q2. How many more students have chosen Maths as their favourite subject, compared to Literacy

Q3. What percentage of students chose Technology as their favourite subject?

Subject	Tally	Frequency
Maths		11
Literacy		9
Science		13
Technology		7

# Answer

Q1.  $\frac{13}{40}$

Q2. 2

Q3. 17.5%

## Topic

Probability

**IDENTIFY WHY CLAIMS ABOUT CHANCE-BASED SITUATIONS MIGHT NOT BE VALID**

## Question

**A school principal claims that the probability of a student passing a test is 80%. However, after reviewing the data, it is found that out of 100 students, only 60 passed the test.**

**Why is the principal's claim about the probability of passing the test invalid?**

## Answer

**The principal's claim of an 80% chance of passing is invalid because the actual data shows that only 60 out of 100 students passed, which is 60%. So, the correct probability of passing is 60%, not 80%.**



## Topic

Probability

### **THE LAW OF LARGE NUMBERS**

## Question

**You flip a coin 10 times and get 7 heads and 3 tails. If you continue flipping the coin many more times, what does the Law of Large Numbers tell you about the results in the long run?**

## Answer

**The Law of Large Numbers tells us that as you flip the coin more and more times, the proportion of heads and tails will get closer to 50% for each. In the long run, the number of heads and tails should be roughly equal.**



# Topic

Probability

## TWO-WAY TABLES

# Question

**A survey of 100 students asked if they prefer coffee or tea. The results are shown in the two-way table below:**

	Coffee	Tea	Total
Male	30	20	50
Female	10	40	50
Total	40	60	100

**What is the probability that a student chosen at random prefers tea?**

# Answer

**The probability is 0.6 or 60%.**



# Topic

Probability

**CONNECT ANTICIPATED DISTRIBUTIONS WITH THEORETICAL DISTRIBUTIONS AND EXPERIMENTAL DISTRIBUTIONS**

# Question

You roll a fair six-sided die 120 times and record the outcomes. Theoretical probability tells us that each number (1 to 6) should appear about  $1/6$  of the time. After rolling the die, you find the following results:

Outcome	1	2	3	4	5	6
Frequency	20	18	22	15	25	20

Compare the experimental distribution (your results) with the theoretical distribution. What do you notice?

# Answer

Theoretical distribution expects each number to appear about 20 times (since  $120/6 = 20$ ). The experimental results are close to this, with most numbers near 20. For example, 4 appeared 15 times and 5 appeared 25 times, but overall, the results are similar to the theoretical distribution.

